

SUMITOMO

SH360LC/380LHD-7 Hydraulic Excavator

 **SUMITOMO CONSTRUCTION MACHINERY CO., LTD.**

731-1 Naganumahara-cho, Inage-ku, Chiba, 263-0001 Japan
 For further information please contact: Phone : +81-43-420-1829 Facsimile : +81-43-420-1907

We are constantly improving our products and therefore reserve the right to change designs and specifications without notice.
 Illustrations may include optional equipment and accessories and may not include all standard equipment.



2301@00T.EA348-1

SUMITOMO

EXCAVATORS

SH360LC-7 SH380LHD-7

- Engine Rated Power (Net): 200 kW
- Operating Weight:
 - SH360LC-7 38,100 kg
 - SH380LHD-7 38,500 kg
- Bucket Capacity (ISO Heaped): 1.7~1.9 m³

HYDRAULIC EXCAVATOR FOR REAL PERFORMANCE

LEGEST



 **JAPANESE TECHNOLOGY**

EU Stage V

Advances Abound. Innovation Infinite.

Setting a new bar for worksite proficiencies. The All-new LEGEST.

The new LEGEST series from Sumitomo has been developed to exceed its own capabilities in every regard, with performance benchmarks that will stand the test of time and innovation to tackle any job. Created for more seamless operations in an extensive range of worksite surroundings, both businesses and operators will come to treasure the performance the LEGEST is capable of providing. Unleash the potential on your worksite with capabilities never before seen.

LEGEST

Advanced Energy Efficiency and Eco-friendly Operation 04-07

- Clean and Fuel-efficient Engine "SPACE 5 α"
- Innovative Hydraulic System "SIH:S α"
- SUMITOMO Technology for Fuel Efficiency

Unparalleled Performance 08-09

Advanced Operator Comfort 10-11

- New Monitor
- New Air Suspension Seat

Sophisticated Safety Features 12-13

- Rear and Right Side Camera

Superior Ease-of-maintenance and Durability 14-16

- Ground Level Access
- EMS

SH380LHD-7 17

Specifications 18-23

**Advances Abound.
Innovation Infinite.**

Advanced Energy Efficiency and Eco-friendly Operation

The combination of the advanced clean engine "SPACE 5 α" and SUMITOMO's proprietary hydraulic system "SIH:S α" achieves much higher operating efficiency and superior fuel economy. These features also mean the excavator is even easier on the environment and worksites.

Faster Operations and Excellent Fuel Economy!

Clean engine **SPACE 5 α** × Innovative hydraulic system **SIH:S α** = **7%* less fuel consumption**

* Comparison of fuel consumption with same workload (SH380LHD-7 SP mode compared against SH370LHD-6 SP mode). The level of reduction may be less than shown above depending on actual job type.

Meets EU Stage V standards

The clean engine "SPACE 5 α" achieves significant reductions in exhaust gas emissions, meeting European Stage V non-road emission standards (EU Stage V), deemed the toughest emissions standards in the world. The SH380LHD-7 series excavator has been designed to be even more environmentally friendly.

NOx: 90% reduction
PM: 92% reduction
(compared to SH370LHD-6)

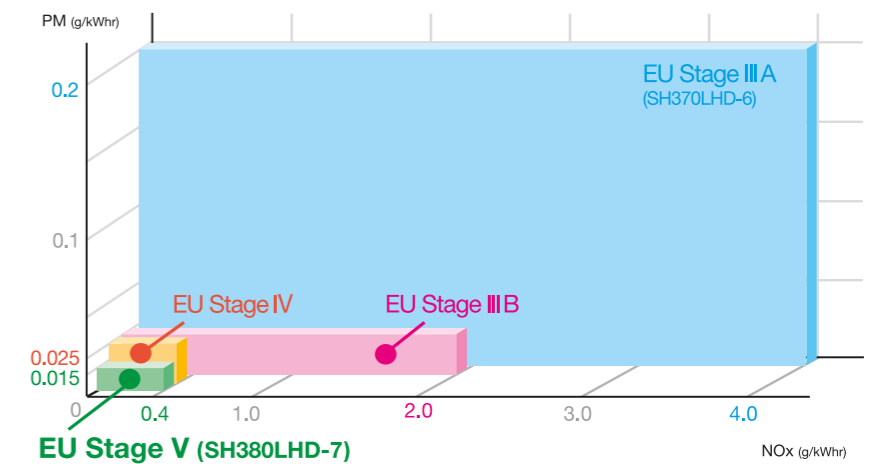

Clean and Fuel-efficient Engine "SPACE 5 α"

The SH380LHD-7 is powered by a new engine designed for significantly improved combustion efficiency and much lower fuel consumption. In addition to a common rail fuel injection system designed for optimum fuel injection, a cooled EGR and VG turbocharger help to achieve cleaner exhaust gas emissions as well as superior power and response.

Exhaust After Treatment System (ATS)

An advanced exhaust after treatment system has been used, featuring a combination of a ceramic filter and SCR. The pre-stage ceramic filter removes PM through collection and combustion, while the post-stage SCR injects AdBlue® (urea water) into the exhaust gas, cleaning the NOx into harmless nitrogen and water through chemical reaction. Post treatment of NOx allows for high-efficiency combustion at the engine, achieving superior clean running as well as powerful and low fuel consumption operation.

AdBlue® is a registered trademark of the German Association of the Automotive Industry.

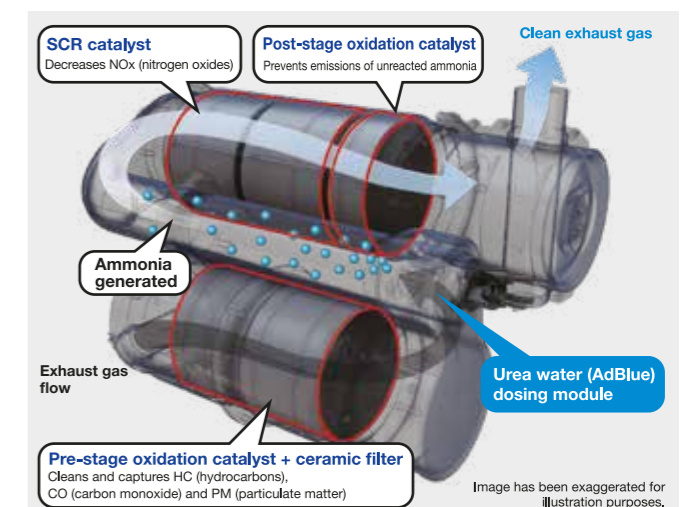

SCR System Design

The SCR system comprises an oxidation catalyst, SCR catalyst and urea water dosing module. The urea water is injected into the exhaust gas, where the NOx is reduced by the SCR catalyst and ammonia generated from the urea water and broken down into harmless nitrogen and water, resulting in clean exhaust gases.

SCR: Selective Catalytic Reduction

**Advances Abound.
Innovation Infinite.**

Advanced Energy Efficiency and Eco-friendly Operation

Innovative Hydraulic System "SIH:S α"

An innovative hydraulic system has been used to reduce fuel consumption, while a fully electronically controlled hydraulic pump ensures precision flow control. Further enhancements have also been made to SUMITOMO's proprietary Spool Stroke Control for optimum hydraulic control to suit job conditions, thus achieving even more efficient operations and significantly lower fuel consumption.

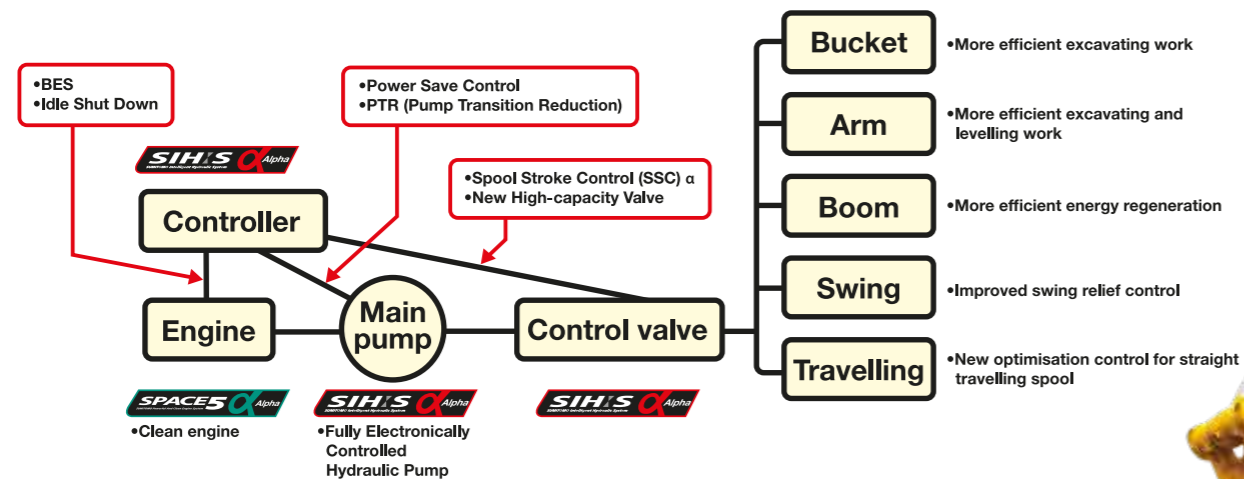

Three Working Modes for Economic Operation or Work Efficiency



Three working modes are available: SP (Super Power) for faster operations, H (Heavy) for heavy duty applications, and A (Auto) for fuel efficiency across a wide range of operations. Six levels are shown for A mode, making it easier to select the right mode for any jobsite.



Integrated Throttle Mode Selector

The throttle mode can be selected by simply turning the knob, so anyone can easily choose the optimum working mode.

SUMITOMO Technology for Fuel Efficiency

•Spool Stroke Control (SSC) α

Automatically adjusts hydraulic pressure to save fuel. Better precision for identifying operating conditions and greater range of control help to reduce fuel consumption and increase operating efficiency even further.

•Fully Electronically Controlled Hydraulic Pump

Designed with ultra-sensitive hydraulic pressure sensing technology for precision flow rate control to suit any type of job. These help to achieve speed, enhance operations and reduce fuel consumption.

•Power Save Control

Reduces the flow rate of the main pump when the machine is not in operation, which cuts down unnecessary fuel consumption.

•BES (Boom-down Energy Save)

Increases fuel efficiency during boom-down operation.

•PTR (Pump Transition Reduction)

Decreases main pump loads to reduce fuel consumption.

•Idle Shut Down & Auto Idle

Detects when the machine is not in operation, and automatically stops the engine from idling. Also equipped with Auto Idle, which automatically switches the engine to idle when the operation levers are in neutral position.



Advances Abound. Innovation Infinite.

Superb Working Efficiency

SUMITOMO
UNIQUE DESIGN

Spool Stroke Control (SSC) ensures a precise, optimum level of flow control to suit working conditions. The machine's speed, power and handling are exactly as the operator intends, which helps to boost working efficiency. The SSC range has been expanded, with better precision for identifying types of operation—the result is both greater energy efficiency and much smoother operation.

Outstanding Operating Speed and Handling

The speed of excavating and filling dump trucks is on an equivalent level to the current SH370LHD-6. The system prioritises controls when work calls for careful handling, thus achieving both high volume and delicate operations.

New High-capacity Control Valve

The valve structure has been improved to significantly reduce pressure loss within internal circuits. Hydraulic oil from the pump is distributed and pumped to actuators efficiently, drastically increasing work speed for both single and combined operations.

Easier Filling Dump Trucks

Filling trucks is easier through the combination of SUMITOMO's proprietary technology* and more powerful boom raising when swinging. This mixes surplus hydraulic pressure when lowering the boom with the arm opening circuit, to empty buckets and excavate soil significantly faster. This makes filling dump trucks much smoother and quicker.

* Boom-down Energy Save boosts the arm opening circuit **SUMITOMO**
UNIQUE DESIGN



Advances Abound. Innovation Infinite.



Advanced Operator Comfort

A comfortable cabin has been designed to reduce operator fatigue, with the aim of relieving stress during work and ensuring greater relaxation during downtime. With features such as a spacious cabin interior, new high-definition monitor with smartphone-like usability, new air suspension seat, and unbelievably quiet operation, the cabin is both comfortable and intuitive to ensure a greater level of safety.

New Monitor—Even More Intuitive and User-friendly

A wide range of excavator operating and maintenance information, warnings and other data are displayed as text messages. Providing a way to view accurate and easy-to-understand information helps to boost operating efficiency and safety.

Illustrations of new monitor displays



Indicators

- 1 Working modes
- 2 Icons
- 3 Warning messages
- 4 Engine coolant temperature
- 5 Fuel level
- 6 Urea water level
- 7 ATS warning
- 8 Camera view (rear camera)
- 9 Camera view (right side camera)

Switch Panel

- A Travel speed button
- B ATS purge
- C Aux. hydraulic settings
- D Window wiper
- E Window washer
- F Work lights
- G Auto idle/Idle stop
- H Display modes
- I Hour meter toggle (trip/total)

Spacious, Class-leading Cabin

Just like previous models, the cabin has been designed with features that are top of its class, all of which help to ensure a comfortable and stress-free space for the operator. Superior sound insulation throughout the cabin translates to top-class levels of silence within.

Console-linked Arm Rest



The arm rest is linked with movement of the tilting console. The distance between the arm rest and operations levers remains the same, regardless of the angle of the console, leading to a greater level of comfort and control.



New Air Suspension Seat

The operator's seat features air suspension as standard for outstanding ride comfort. A new high-performance reclining seat with higher seatback has been used to ensure premium comfort. A multitude of seat adjustments and ample seat cushion width all help to significantly lower operator fatigue. The high water-repellent seat material is also easier to keep clean.



Seat air suspension

Premium Comfort with Seat Heater (OPTION)

A seat heater function is now available as an optional extra for even greater comfort in cold seasons or working early mornings. A convenient seat tilting function has also been added that allows the seat cushion to be tilted forward or back to suit the operator's body type or particular job—now anyone can achieve the optimum seating posture for more comfortable control.



Seat heater switch

Automatic Air-conditioner

Fully automatic climate control maintains a comfortable temperature within the cabin. The optimal ducting layout and airtight cabin also help to boost air-conditioning efficiency.



Equipment for Comfort and Safety



Rear luggage space

Hot & cool box

Magazine rack

Anti-theft system

Emergency stop switch

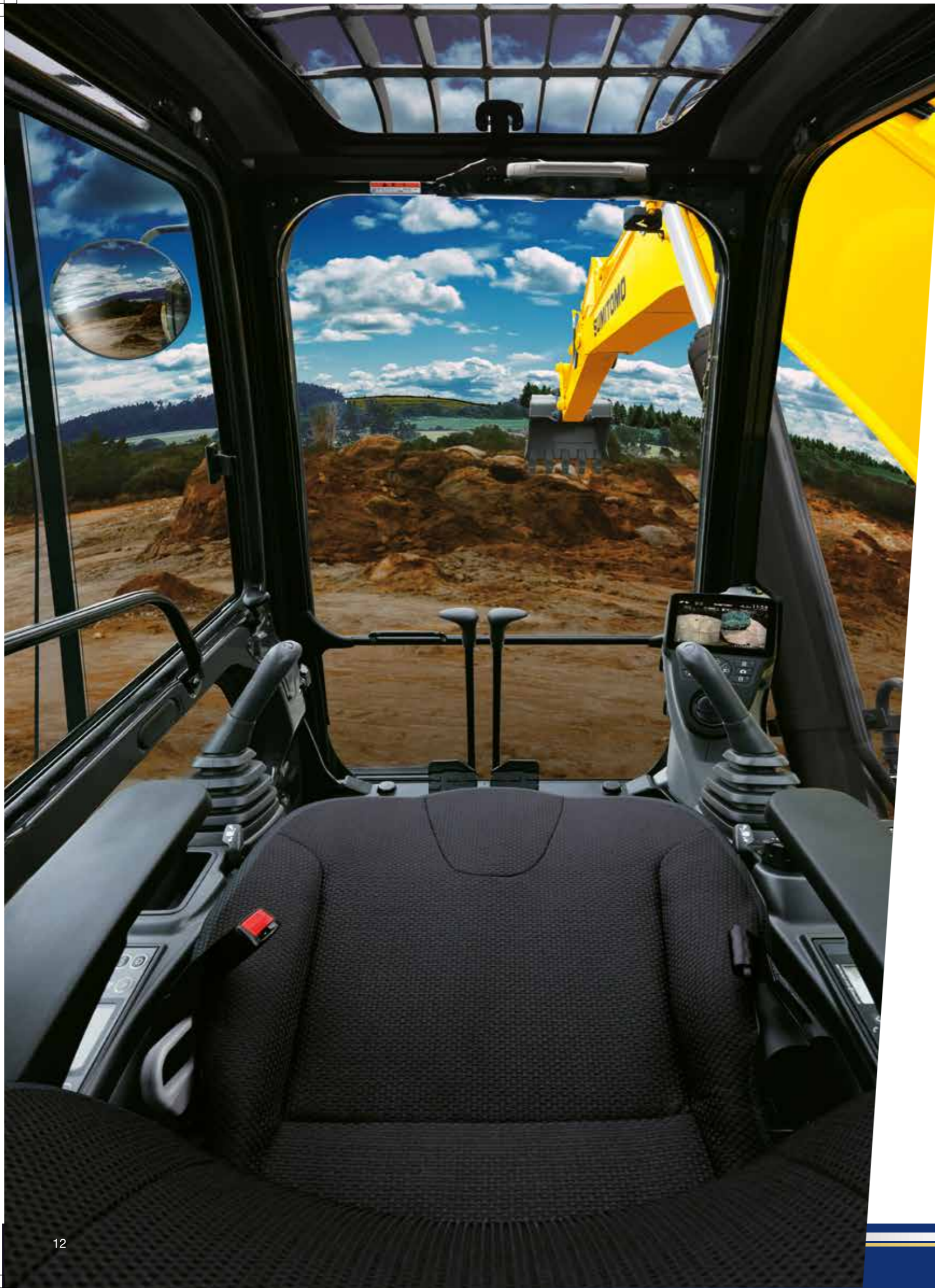

Sophisticated Safety Features

The cabin provides excellent driving visibility, and features a high-strength design to better protect the operator. Every aspect has been designed for day-to-day safety, including excellent access in and out of the cabin, and steps and handrails to make inspections and maintenance easier. The use of rear and right side cameras also helps to ensure operations remain safe.

Safe ROPS-compliant Cabin

A high-strength cabin design means operators are even better protected. ROPS: Roll-Over Protective Structure

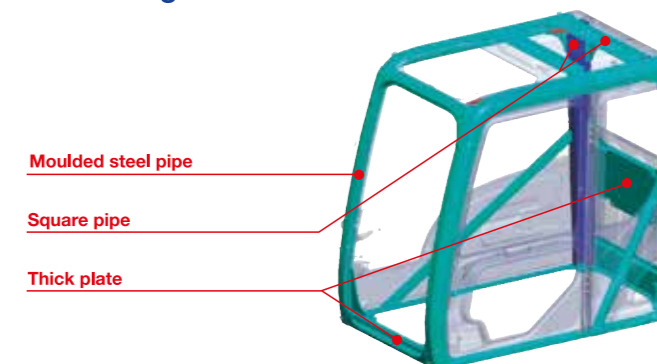

Wide View for Excellent Site Safety

In addition to the front of the excavator, the cabin design gives the operator a wide, unrestricted view to check upper and lower areas. Direct visibility for the operator means work can be performed safer.



Superb Access

The wide door opening and large handrails provide excellent access up to and down from the cabin. The spacious footwell also makes it easier to get in and out.



Large handrail and spacious footwell

Rear and Right Side Cameras

Two cameras are installed as standard—rear view and on the right side—so the operator can check for safety behind the excavator. Optimally positioned mirrors and the use of cameras ensure that mirror visibility meets ISO standards, thus making it easier for the operator to check for safety in any desired direction.



Monitor videos

Handrails and Non-slip Plates for Operator Safety

Steps and handrails are in the optimal positions to assist getting in and out of the cabin and to ensure safety during inspections and maintenance. New handrails have now also been installed at the rear of the cabin and the right side of the body, while non-slip plates improve safety when it is raining.



Handrails

Non-slip plates



Rear camera



Right side camera

LED Cabin Top Light (OPTION)

A long-life LED cabin top light is now available as an optional extra. Super bright and with a high-visibility colour, the light enhances safety during night-time operations.



LED cabin top light

**Advances Abound.
Innovation Infinite.**



Superior Ease-of-maintenance and Durability

Easy maintenance and durability are the key to excavators that are called upon for ongoing work at job sites. With enhanced durability at every corner and proprietary EMS, outstanding reliability is standard with SUMITOMO excavators—they are designed to be easy to operate and maintain for customers, including features like ground level access and refilling AdBlue®.

Ground Level Access for Easy Inspections and Maintenance

Components requiring inspection are all in a central location, meaning inspections and refilling can be performed without having to climb up onto the excavator.

•Increased Cooling Performance

The use of a larger radiator and oil cooler help to increase cooling performance and reliability. It is also easier to clean the dust-proof net.

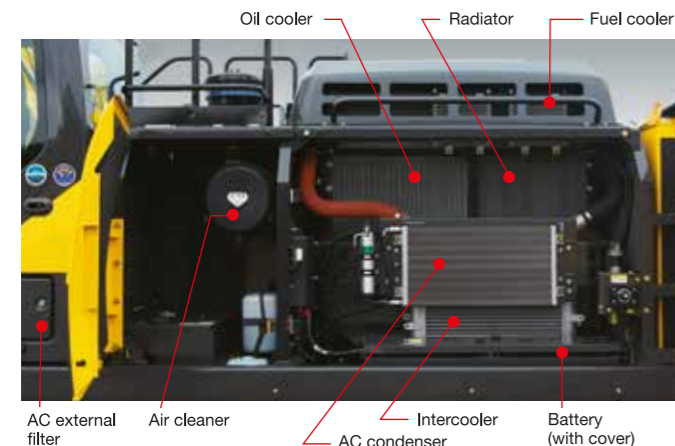

Battery Cutoff Switch

A battery switch is mounted inside the inspection cover, ensuring safe operations during maintenance procedures.



•Designed for Easy Filter Replacement

The pre-fuel filter is designed to reduce issues due to a blocked fuel filter, and the easily accessible location of the fuel and oil filters ensure smooth inspection and replacement work.

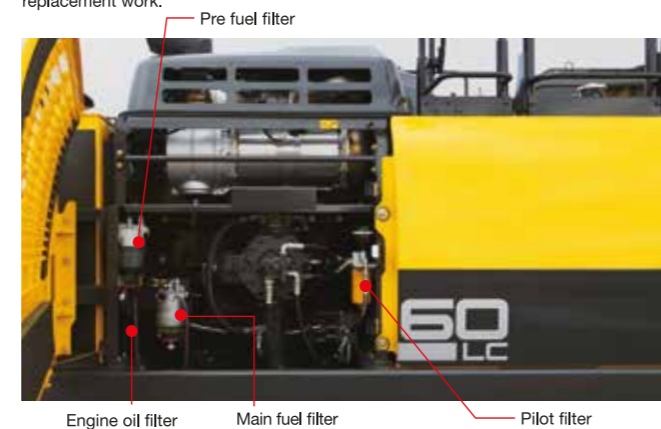

Other Maintenance Features



Dust-proof Net for Enhanced Maintenance

A dust-proof net mounted in front of the radiator and cooler reduces the amount of dust adhesion, leading to a higher level of reliability. The dust-proof net can be removed from the front for easy cleaning.



High-Performance Return Filter

A long hydraulic oil change interval of 5,000 hours, and the use of a high-performance return filter ensures superior ease-of-maintenance.

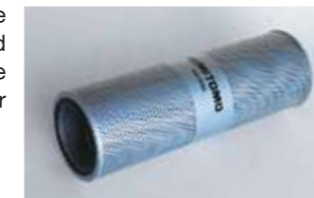

Hydraulic oil change: **5,000** hours
Filter life: **2,000** hours

* The oil and filter change intervals vary depending on operating conditions.

Easy-to-fill Urea Tank

The urea tank has been positioned near the front right for easy refilling, to suit the way the excavator is used. In addition to easily refilling water by climbing up on the side frame, water can also be refilled by placing the AdBlue® container in front of the tank.



Urea Tank Capacity: **152 L**
Refilling frequency: **Once** per **8** refuellings

A large capacity tank has been used for longer refilling intervals and lower the amount of associated work. The tank needs to be refilled around once every eight times the fuel tank is filled (may vary depending on usage conditions).

Precautions with machines installed with the SCR System

To ensure that the machine can be used safely and smoothly, use AdBlue® aqueous solution (or a urea aqueous solution that complies with ISO standards). Using a non-standard aqueous solution or diluting the solution before use may cause mechanical problems. Malfunctions arising from the use of non-standard aqueous solutions are not covered by SUMITOMO's warranty service.

- The remaining AdBlue® level can be checked during work on the monitor display in the cab. A warning is displayed on the monitor when the remaining level becomes low or there is an issue with quality.
- The engine power output will be limited if the remaining AdBlue® level falls below the minimum level or there is an issue with quality, so be sure to plan refills in advance.

Precautions when handling AdBlue®

- The SCR System is designed exclusively for the machine, and must not be used for any other purpose.
- Rinse with water any solution that comes in contact with skin.
- When storing the solution, always use sealed containers and store at room temperature in a well-ventilated location out of direct sunlight.
- When carrying the solution, always use the container that the solution was purchased in, or other specified container.
- The SCR System includes a heater function, however sufficient care must be taken to prevent freezing when the solution is stored in cold regions (freezing temperature: -11°C).



Example monitor warning display

Read the instruction manual for more details.

**Advances Abound.
Innovation Infinite.**

SH380LHD-7



EMS for Enhanced Maintenance of Joints SUMITOMO UNIQUE DESIGN

SUMITOMO's EMS (Easy Maintenance System) has been used to ensure the excavator is always at the forefront of any work site. Special bushes keep joints lubricated and prevent rattling, and help give parts like bushes and pins a longer operating life.

Greasing interval for other sections: **1,000 hours**

* The greasing interval varies depending on operating conditions.



Attachment EMS bushing with self-lubricating capability

Higher Rigidity Boom and Arm

The boom and arm essential for operations feature a heavy-duty design and optimally shaped structure for greater strength and durability, as well as enhanced reliability of joints.

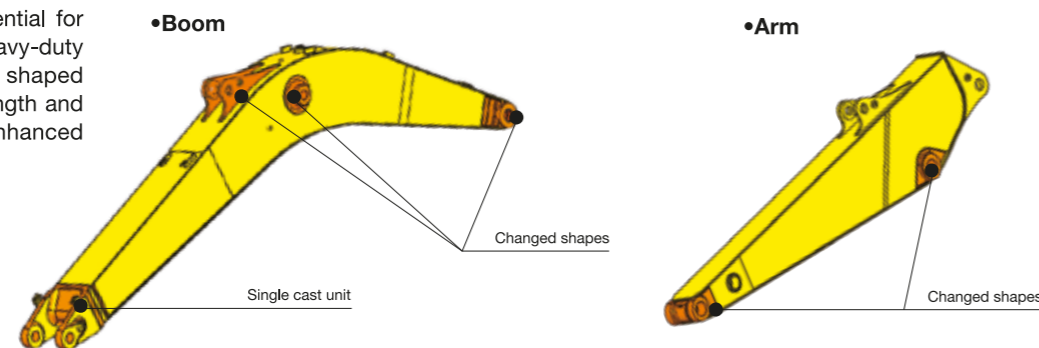

Superior Undercarriage Cleanout

A linear angled shape for the upper side frame is designed to make it easier to clean out debris from the undercarriage.

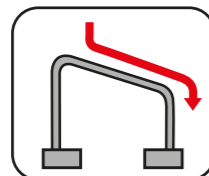

■ Upper side frame shape
Image has been simplified for illustration purposes.

Enhanced Undercarriage for Greater Durability and Easier Maintenance

Durability of the undercarriage has been enhanced with improvements to the track rollers and front idlers. Better interior sealing also increases sediment resistance.

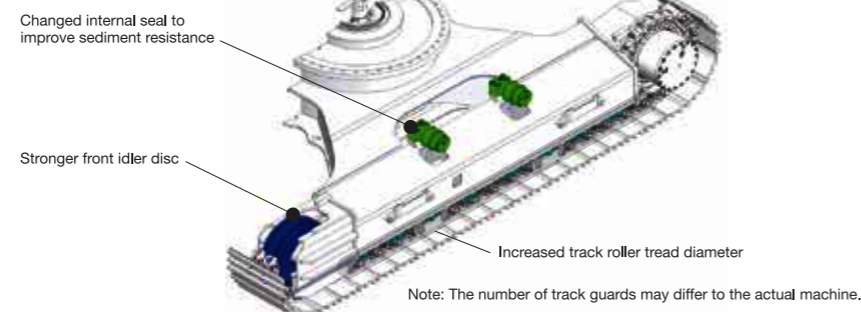

Note: The number of track guards may differ to the actual machine.

Heavy Duty Specifications SH380LHD-7

“Heavy Duty (HD) specifications” designed for harsh worksites. Tough, rigid body and dependable power bring out the machine’s full potential.

● SH380LHD-7 exclusive accessories

Front Guard & Head Guard (OPTION)

A front guard and head guard is available to protect the cab from falling rocks or debris.



Side Deck Guard

Guards mounted on both side decks of the machine protect against collisions or shocks.



Arm Lock Guard

A lower guard mounted at the arm tip protects against denting when carrying rocks.



High-durability Bucket

A high-durability bucket is installed as standard for the HD spec machine, providing added reliability on tough worksites.



Full Track Guard

A full track guard along the lower undercarriage prevents shoes riding off, and also helps to protect the rollers.



Specifications

SH360LC/SH380LHD-7 Technical Data

The electronic-controlled engine of S PACE 5 α and SH:S α with New Hydraulic System includes: three working modes (SP, H and A), one-touch/automatic idling system, automatic power-boost, speed assistance system, power-swing system.

Engine

SH360LC/SH380LHD-7	
Model	ISUZU VE-6HK1X
Type	Water-cooled, 4-cycle diesel, 4-cylinder in line, high pressure common rail system (electric control), turbocharger with air cooled intercooler, ATS
Rated output	200 kW at 1,900 min ⁻¹
Maximum torque	988 N·m at 1,500 min ⁻¹
Piston displacement	7.79 ltr (7,790 cc)
Bore and stroke	115 mm x 125 mm
Starting system	24 V electric motor starting
Alternator	24 V, 90 A
Air filter	Double element

Hydraulic pumps

Two variable displacement axial piston pumps provide power for boom/arm/bucket, swing, and travel. One gear pump for pilot controls.

SH360LC/SH380LHD-7	
Maximum oil flow	2 x 300 ltr/min
Pilot pump max. oil flow	28.5 ltr/min

Hydraulic motors

Two variable displacement axial piston pumps provide power for boom/arm/bucket, swing, and travel. One gear pump for pilot controls.

Working circuit pressure

Boom/arm/bucket34.3 MPa
 Boom/arm/bucket37.3 MPa with auto power-up
 Swing circuit30.4 MPa
 Travel circuit34.3 MPa

Control valve

With boom/arm holding valve
 One 4-spool valve for right track travel, bucket, boom and arm acceleration
 One 5-spool valve for left track travel, auxiliary, swing, boom acceleration and arm

Oil filtration

Return filter 6 microns
 Pilot filter 8 microns
 Suction filter 105 microns

Hydraulic cylinders

SH360LC/SH380LHD-7		
Cylinder	Q'ty	Bore x rod diameter x stroke
Boom	2	145 mm x 100 mm x 1,495 mm
Arm	1	170 mm x 120 mm x 1,748 mm
Bucket	1	150 mm x 105 mm x 1,210 mm

Double-acting, bolt-up-type cylinder tube-end; hardened steel bushings are installed in the cylinder tube and rods ends.

Cabin & controls

The cabin is mounted on four fluid mountings. Features include safety glass front, rear and side windows, adjustable upholstered suspension seat with headrest and armrest, cigarette lighter, pop-up skylight window, and intermittent wiper with washer.
 The front window slides upward for storage, and the lower front window is removable. Control levers are located in four positions with tilting control consoles. Built-in type full-colour monitor display. Membrane switch on monitor display.

Swing

Planetary reduction is powered by an axial piston motor. The internal ring gear has a grease cavity for pinion. The swing bearing is a single-row shear type ball bearing. Dual stage relief valves are used for smooth swing deceleration and stops. A mechanical disc swing brake is included.

SH360LC/SH380LHD-7	
Swing speed	0 ~ 9.7 min ⁻¹
Tail swing radius	3,540 mm
Swing torque	112 kN·m

Undercarriage

An X-style carbody is integrally welded for strength and durability. The grease cylinder track adjusters have shock absorbing springs. The undercarriage has lubricated rollers and idlers.

Type of shoe: sealed link shoe

Upper rollers -

Heat treated, mounted on steel bushings with leaded tin bronze casting, sealed for lifetime lubrication.

Lower rollers -

Heat treated, mounted on steel bushings with leaded tin bronze casting, sealed for lifetime lubrication.

Track adjustment -

Idler axles adjusted with grease cylinder integral with each side frame; adjustment yoke mechanism fitted with heavy duty recoil spring.

Number of rollers and shoes on each side

SH360LC/SH380LHD-7	
Upper rollers	2
Lower rollers	8
Track shoes	48

Travel system

Two-speed independent hydrostatic system with compact axial motors for increased performance. Hydraulic motor powered output shaft coupled to a planetary reduction unit and track sprocket. All hydraulic components mounted within the width of side frame. Travel speed can be selected by the switch panel on the monitor display. Hydraulically released disc parking brake is built into each motor.

SH360LC/SH380LHD-7		
Travel speed	High	5.7 km/h
	Low	3.4 km/h
Drawbar pull	264 kN	

Lubricant & coolant capacity

SH360LC/SH380LHD-7	
Hydraulic system	350 ltr
Hydraulic oil tank	175 ltr
Fuel tank	590 ltr
Cooling system	38 ltr
Final drive case (per side)	9.5 ltr
Swing drive case	5.0 ltr
Engine crank case (with remote oil filter)	49 ltr
Urea water tank	152 ltr

Auxiliary hydraulic system

SH360LC/SH380LHD-7			
Auxiliary piping type (option)	For Breaker	For Double (breaker & crusher) acting	For D/A + Second option line STD
Arm type	HD	HD	HD
Bucket linkage type	HD	HD	HD
Auxiliary hydraulic pump flow	300 ltr/min	600 ltr/min	600+62 ltr/min

Bucket

Options and specifications may differ depending on countries and regions

Model		SH360LC-7	SH380LHD-7
Bucket capacity (ISO/SAE/PCSA heaped)		1.7 m ³	1.9 m ³
Bucket type		HD ROCK	HD ROCK
Number of teeth		5	5
Width	With side cutter	—	—
	Without side cutter	1,325 mm	1,465 mm
Weight		1,667 kg	1,765 kg
Combination	2.63 m arm	◎	◎
	3.25 m arm	●	●

◎ Suitable for materials with density up to 2,000 kg/m³ or less

● Standard bucket (Suitable for materials with density up to 1,800 kg/m³ or less)

Weight & Ground Pressure

Model		SH360LC-7			
Shoe type	Shoe width	Overall width	Operating weight	Ground pressure	
Triple grouser shoe	600 mm	3,200 mm	38,100 kg	71 kPa	

Model		SH380LHD-7			
Shoe type	Shoe width	Overall width	Operating weight	Ground pressure	
Triple grouser shoe	600 mm	3,200 mm	38,500 kg	72 kPa	

Digging Force

Model		SH360LC/SH380LHD-7	
Arm length		2.63 m	3.25 m
Bucket digging force <with auto power up>	ISO 6015	225 kN <244 kN>	
Arm digging force <with auto power up>	ISO 6015	194 kN <211 kN>	164 kN <178 kN>

Principle Specifications

	SH360LC-7	STD Specifications	SH380LHD-7
	ISUZU VE-4HK1X		
Base	6.45 m		
Boom length	6.45 m		
Arm length	3.25 m		
Bucket capacity (ISO heaped)	1.7 m ³		1.9 m ³
Std. operating weight	38,100 kg		38,500 kg
Engine	ISUZU VE-4HK1X		
Make & model	ISUZU VE-4HK1X		
Rated output	200 kW/1,900 min ⁻¹		
Displacement	7.79 ltr		
Hydraulic System	2 variable displacement axial piston pumps with regulating system		
Main pump	2 variable displacement axial piston pumps with regulating system		
Max pressure	34.3 MPa		
/with auto power boost	37.3 MPa		
Travel motor	Variable displacement axial piston motor		
Parking brake type	Mechanical disc brake		
Swing motor	Fixed displacement axial piston motor		
Travel speed	5.7/3.4 km/h		
Drawbar pull	264 kN		
Gradeability	70% <35°>		
Performance	71 kPa		72 kPa
Ground pressure			
Swing speed	9.7 min ⁻¹		
Bucket digging force	225 kN		
/with power boost	244 kN		
Arm digging force	164 kN		
/with power boost	178 kN		
Others	590 ltr		175 ltr
Fuel tank	152 ltr		
Hydraulic fluid tank			
Urea water tank			

Standard Equipment

[Hydraulic system]

- SIH:S α hydraulic system
- Operation mode (SP, H and A mode)
- Automatic 2-speed travel
- Automatic power boost
- Boom/arm holding valve
- Arm/boom/bucket reactivation circuit
- Automatic swing parking system
- Auxiliary valve
- High-performance return filter

[Cabin/interior equipment]

- Shock-less cab suspension by 4-point fluid mounts
- New full-colour LCD monitor
- Tilting console
- Fresh-air intake pressurised full-automatic air conditioner
- Defroster
- Hot & cool box
- High water-repellent seat
- Seat suspension
- Armrest & headrest
- Windscreen wiper (with intermittent operation function)
- Cup holder
- Magazine rack
- Accessory case
- Floor mat
- Ashtray & cigarette lighter
- Cab light (Auto-OFF function)
- Coat hook
- Operation lever with one-touch wiper switch
- Polycarbonate roof top window with sunshade
- 12V power (DC-DC converter)

[Safety equipment]

- ROPS cab (FOPS level 1)
- Head guard (OPG Level 2)
- Rear/right side camera
- Rearview mirror (left/right)
- Emergency escape tool
- Retracting seat belt
- Gate lock lever (engine neutral start)
- Travel alarm
- Anti-theft alarm system
- Engine room firewall
- Fan guard
- Engine emergency stop switch

[Others]

- Auto/one-touch idling
- Auto idle shutdown system
- EMS
- Long-life hydraulic oil
- Five lights (chassis, left/right of boom, cab)
- Fuel filter (with water separator and clogging sensor)
- Fuel pre-filter (with water separator)
- Double-element air cleaner
- Grease-enclosed track link
- Large tool box
- A set of tools
- Pre-air cleaner

Accessories (option)

■ Cab-top lights (LED)



■ Camera lights (LED) (top: side, bottom: rear)



■ Rain deflector



■ Sun visor



■ Front mesh guard (full)



■ Front guard (OPG level 1 or 2)



■ Refuel pump

■ Hose burst check valve (HBCV) for boom/arm cylinders

Accessories and specifications may differ depending on countries and regions.

Working Range

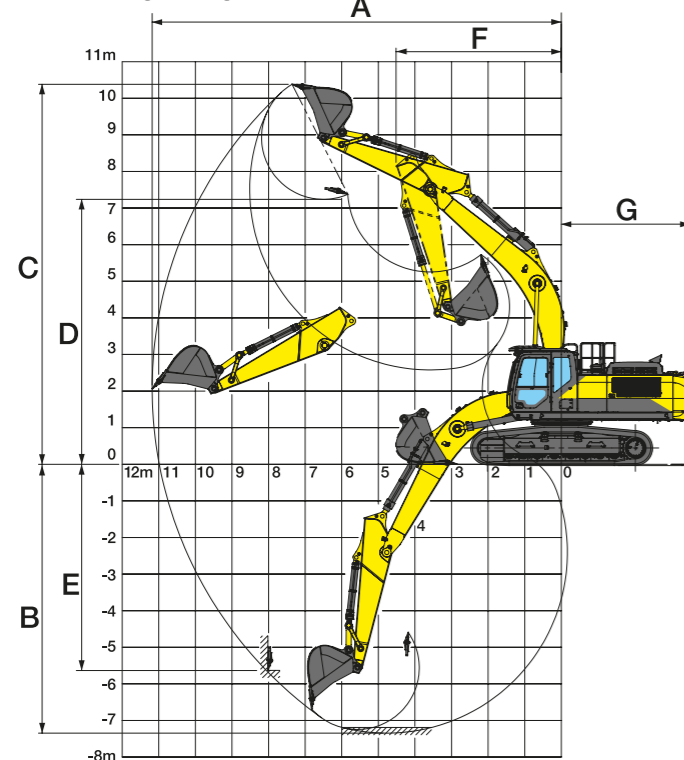

	SH360LC/SH380LHD-7	
Arm length	2.63 m	3.25 m
Boom length	6.45 m	
A Max. digging radius	10,660 mm	11,180 mm
B Max. digging depth	6,730 mm	7,350 mm
C Max. digging height	10,290 mm	10,380 mm
D Max. dumping height	7,100 mm	7,240 mm
E Max. vertical wall cut depth	5,360 mm	5,630 mm
F Min. front swing radius	4,440 mm	4,520 mm
G Rear end swing radius	3,540 mm	

Dimensions

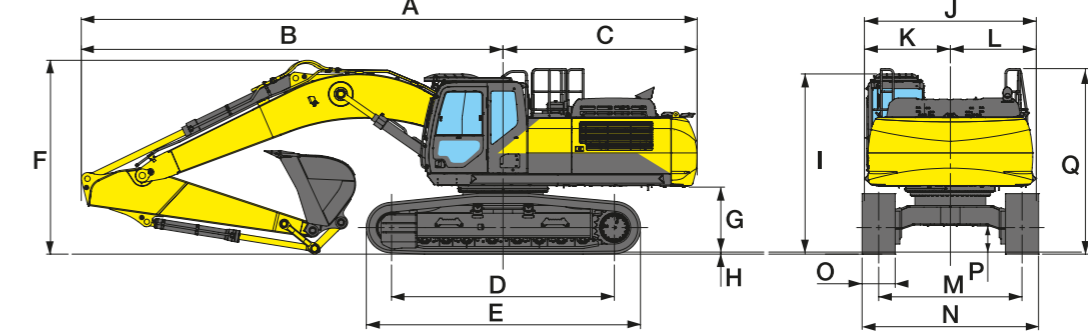

Model	SH360LC-7		SH380LHD-7	
Arm length	2.63 m	3.25 m	2.63 m	3.25 m
A Overall length	11,220 mm	11,170 mm	11,220 mm	11,170 mm
B Length from centre of machine (to arm top)	7,700 mm	7,650 mm	7,700 mm	7,650 mm
C Length from centre of machine (to rear end)	3,520 mm			
D Centre to centre of wheels	4,040 mm			
E Overall track length	4,980 mm			
F Overall height	3,670 mm	3,510 mm	3,670 mm	3,510 mm
G Clearance height under upper structure	1,180 mm			
H Shoe lug height	36 mm			
I Cab height	3,270 mm			
J Upper structure overall width	3,030 mm		3,120 mm	
K Width from centre of machine (left side)	1,540 mm		1,560 mm	
L Width from centre of machine (right side)	1,490 mm		1,560 mm	
M Track gauge	2,600 mm			
N Overall width	3,200 mm			
O Std. shoe width	600 mm			
P Minimum ground clearance	470 mm			
Q Handrail height	3,360 mm			